

Kuzma **Air Line** Tonearm

# The Air Line Tonearm

## A linear tangential arm incorporating

an air bearing which ensures practically zero friction in movement while still maintaining a rigid bearing.

The cartridge thus follows the same straight line as did the cutter head while cutting the record grooves.

The Kuzma AIR LINE tonearm is the result of a combination of experience making top-class, conventional radial tonearms and new research into air bearing technology. The air bearing used is the same as those used in precision measuring and tool making machines, which demand the highest accuracy possible in frictionless movement and positioning. The gap between the shaft and bearing is only 10 microns.

Pressurized air is supplied by one of the quietest compressors available, along with an air-drying unit. It is best positioned outside the listening room and connected by a thin plastic tube provided. The AIR LINE tonearm also has a rigid, minimally resonating aluminum structure, and is easy to adjust, with repeatable VTA and azimuth adjustments. It is possible to order the tonearm wired in a balanced configuration.

We believe that using the AIR LINE tonearm will be the single greatest leap you can make to improve the quality of sound reproduction in your analogue system.

### AIR LINE - Linear tracking air bearing tonearm

**Effective length:** 184 mm

**Fixing distance to Mounting distance:**  
Kuzma (212 mm)

**Effective mass:** 13 g vertical

**Minimum clearance below platter:** 30 mm

**Height adjustment:** yes

**VTA fine adjustment:** 10 mm

**Azimuth fine adjustment:** yes

**Damping:** yes

**Air bearing:** diameter 20 mm x 50 mm

**Load axial or radial:** 30 N (approx. 3 kg)

**Air pressure:** 4 bar (60 psi)

**Air consumption:** 4 l/min

**Mass:** 2 kg (4.4 lb)

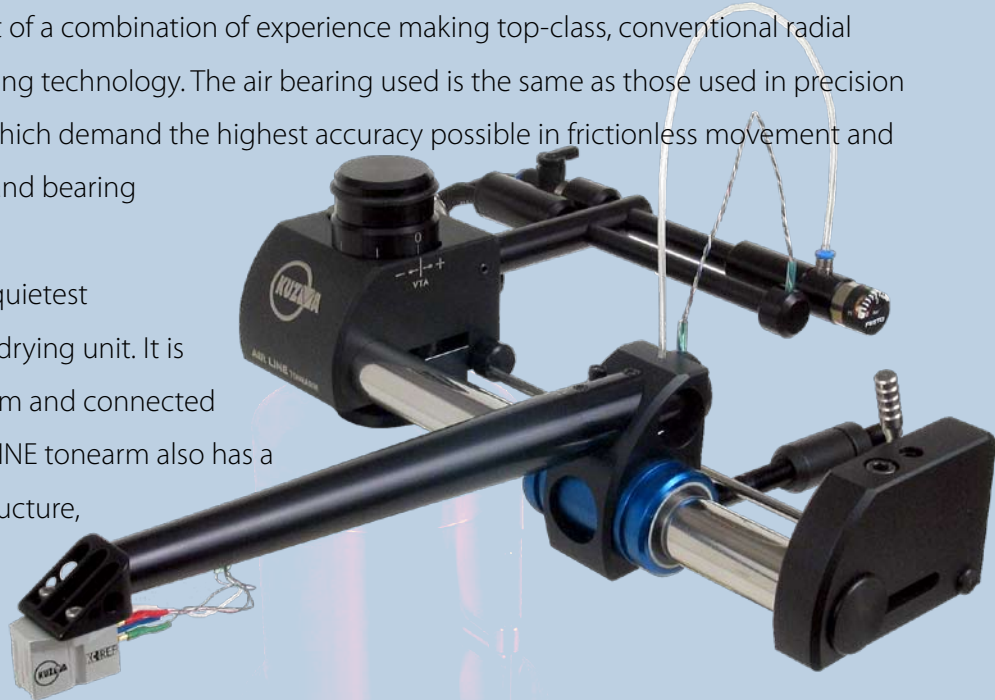

KUZMA Ltd • Hotemaze 17 a • SI-4205 Preddvor, Slovenia  
• tel.: +386 4 253 54 50 • fax: +386 4 253 54 54  
• www.kuzma.si • e-mail: kuzmaltd@siol.net